



- Dumper simple tracción
- Chasis rígido
- Opcional descarga en contenedores y autocargable
- Capacidad de carga 1500 Kg

Características Técnicas		
<b>Capacidad de carga:</b>	1500kg	
<b>Motor:</b>	Marca	DEUTZ-DITER
	Modelo	D 909 L01
	Nº de cilindros	1
	Potencia máxima	11Kw (15CV) a 3000 r.p.m.
	Tipo de refrigeración	Refrigerado por aire
<b>Transmisión</b>	Mecánica, caja de cambios con 4 velocidades hacia delante y 4 hacia atrás con inversor mecánico	
<b>Freno de servicio</b>	Frenos herméticos , mecánicos de tambor en ruedas motrices	
<b>Dirección</b>	Hidráulica por orbitrol	
<b>Ruedas delanteras</b>	Neumáticos de altas prestaciones para tierra 750x16	
<b>Ruedas traseras</b>	145-Sr 13	
<b>Tara</b>	880kg	
<b>Radio de giro interior</b>	2.4m	
<b>Radio de giro exterior</b>	3.4m	
<b>Velocidad máxima</b>	17km/h	
<b>Pendiente máxima superable</b>	53% asfalto / 40% compacta	
<b>Pala autocargable</b>	Opcional	
<b>Capacida pala autocargable</b>	110l	

# DUMPER V-1500

## CHASIS RÍGIDO-TRACCIÓN DELANTERA



### DIMENSIONES

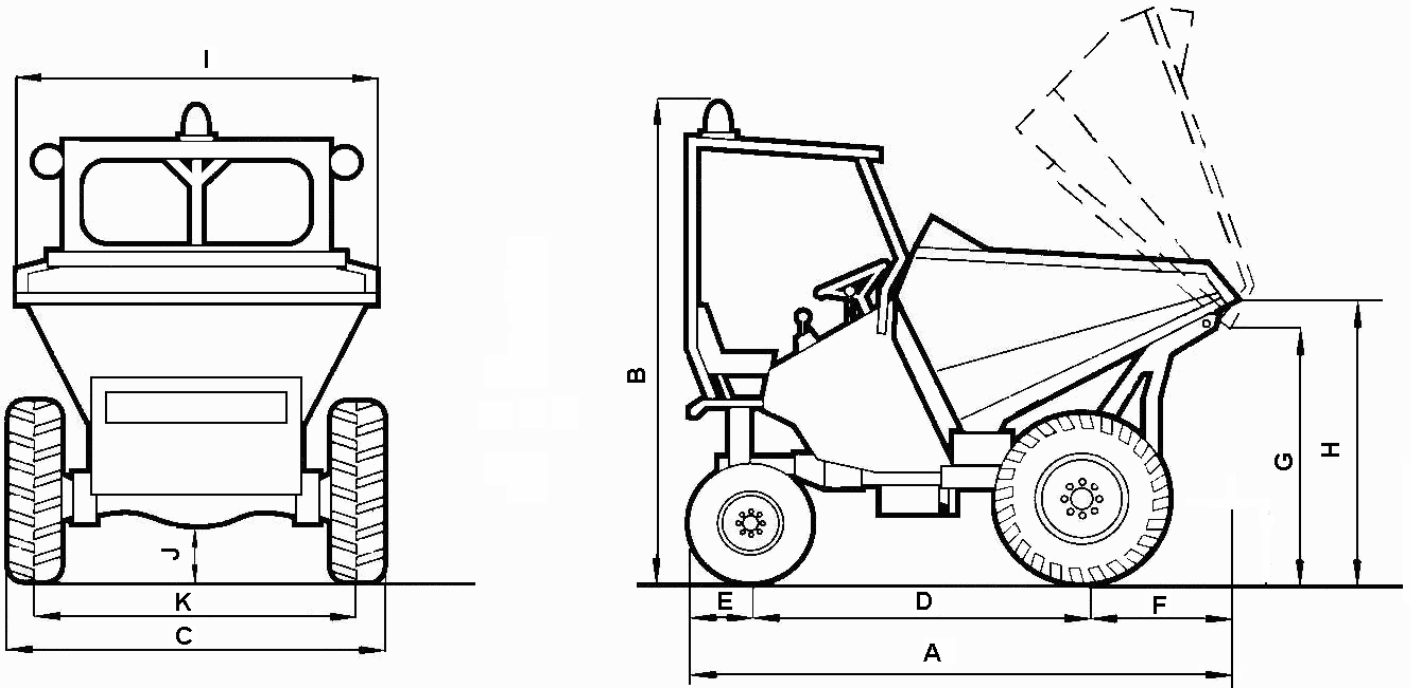

A	2460mm	
B	2060mm	
C	1525mm	
D	1560mm	
E	285mm	
F	615mm	
G	Descarga frontal	430mm
	Descarga en contenedores	1200mm
H	1140mm	
I	1445mm	
J	250mm	
L	1230mm	



# DUMPER V-1500

## CHASIS RÍGIDO-TRACCIÓN DELANTERA



### RADIO DE GIRO

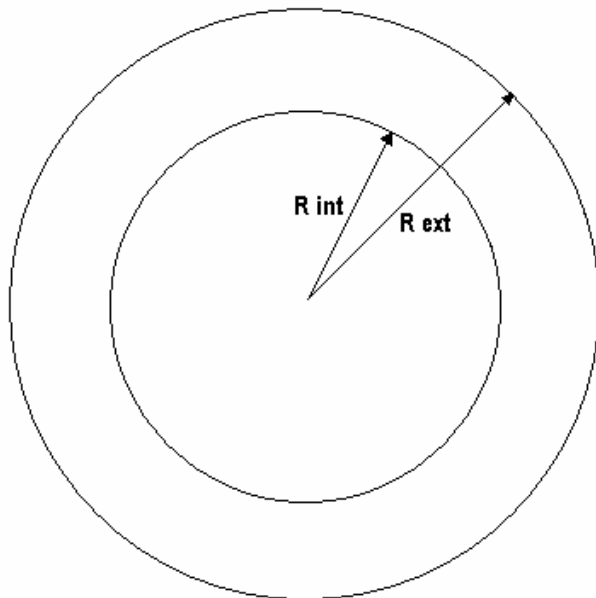

RADIO DE GIRO	
Radio exterior (m)	3,4
Radio interior (m)	2,4

### TOLVA

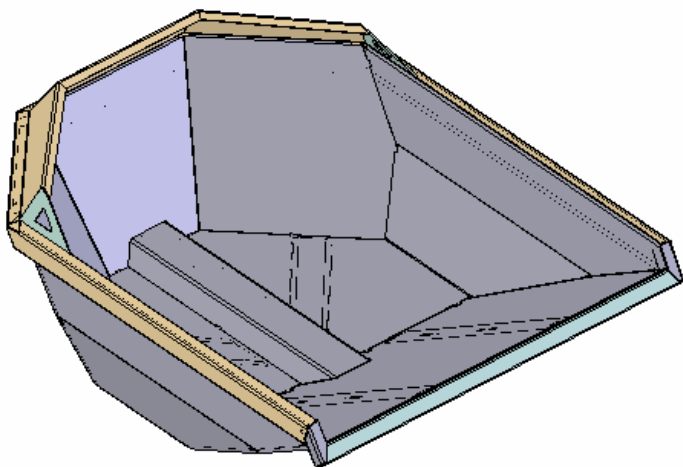

CAPACIDAD	
CAPACIDAD	Agua – 700 l
	Enrasada – 950 l
	Colmada – 1250 l



# DUMPER V-1500

## CHASIS RÍGIDO-TRACCIÓN DELANTERA



### MOTOR



#### Engine type

**D 909 L 1**

Number of cylinders		1
Bore/Stroke	mm	95/100
Displacement	l	0.7
Compression ratio		17
Max. rated speed	rpm	3000
Mean piston speed	m/s	10.0

#### Power ratings for construction equipment engines

Power ratings for automotive <sup>1)</sup> and industrial engines	kW	11
at speed	rpm	3000
Mean effective pressure	bar	6.21
Intermittent operation	kW	10.5
at speed	rpm	3000
Mean effective pressure	bar	5.93
Max. torque	Nm	38.2
at speed	rpm	2000
Minimum idle speed	rpm	850
Specific fuel consumption <sup>3)</sup>	g/kWh	236
Weight to DIN 70020, part 7A <sup>4)</sup>	kg	106



C/ Arnao, 15 - Polígono Industrial de Barres  
33794 - Castropol - Asturias  
España  
Tlf: 985 471 063  
Fax: 985 472 709  
[www.uromac.com](http://www.uromac.com)